

PS65-DLC - Lift Column

*Industrial Grade Powered Lift Column
for Screens From 32" to 65"*

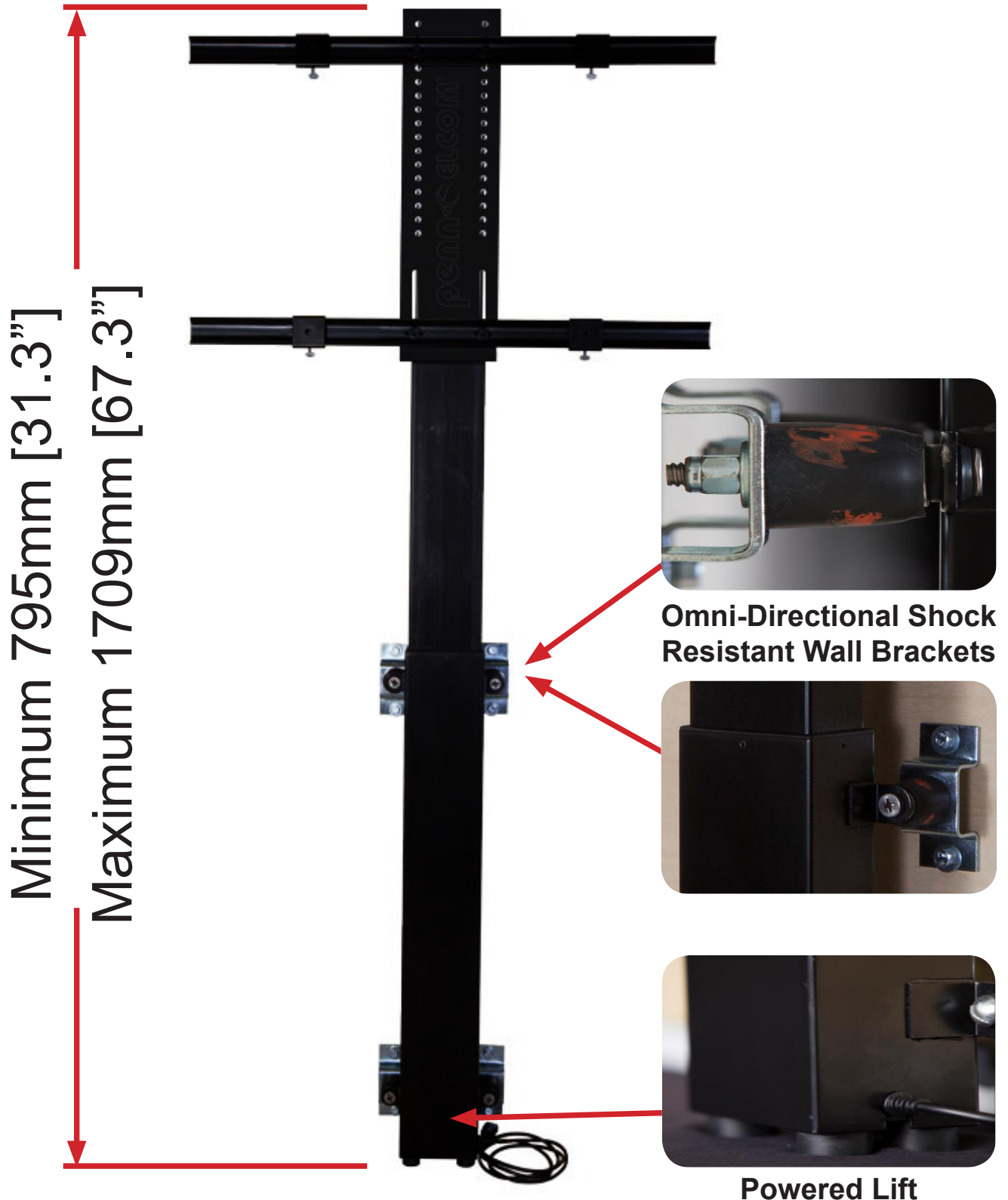

LIFT COLUMN PS65-DLC

Lift Column



Note: dimensions do not include wall dampeners.
Dimensions (mm).

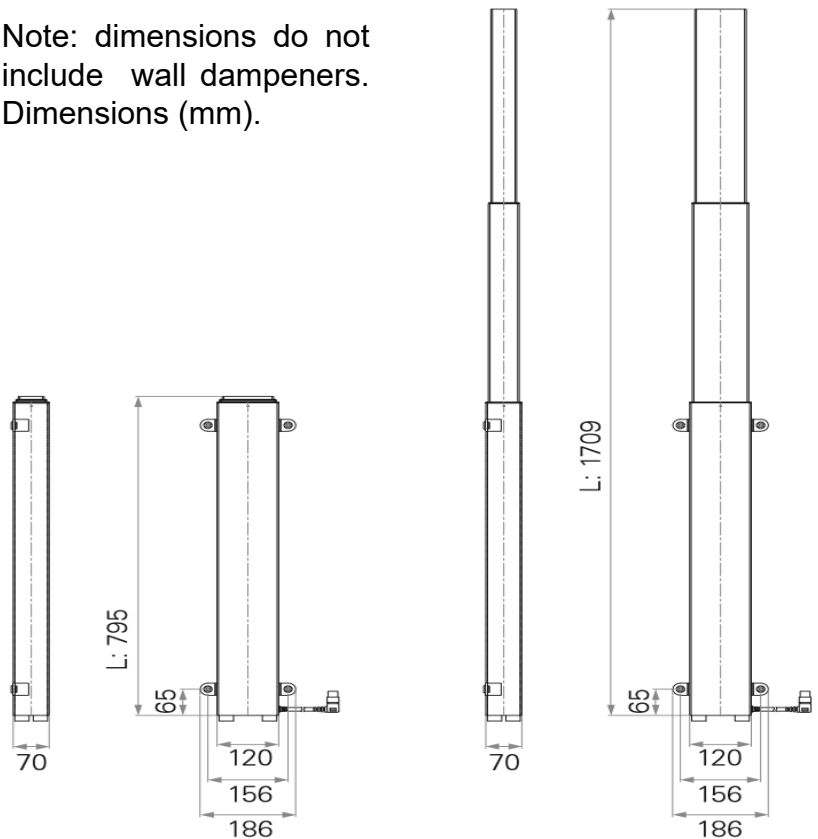

Control Box

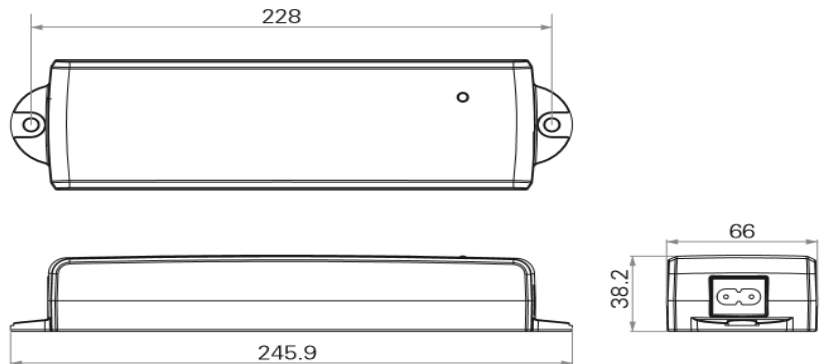

Wired Hand Controller



General Features

Maximum Load: 135lbs
VESA: 100x100mm - 600x400mm
Max Speed at Full Load: .866"/sec
Certificate: RoHS

Vertical Travel: 36"
Column Height: 48.1"
Max Screen Size: 65" Total
Travel Time: 35 Sec.

Limited Warranty: 5yrs. on Column, 2yrs. On Control Box and Hand Controller. The Limited Warranty covers manufacturing defects in the products from date of production. Improper operation, installation, over-spec applications, function failure caused by other assembled products, unexpected natural calamity or aggressive use is not covered.

Manufactured by BALD Technologies, INC. www.baldtechnologies.com